

We do not see light,  
 we only see slower things  
 lit by it,  
 so that for us  
 light is on the edge  
 the last thing we know  
 before things become too swift  
 for us.

C.L. Lewis

# Background Hum

Spring 2005

Volume I Issue I

DEPARTMENT OF ELECTRICAL ENGINEERING

IIT BOMBAY

## Inside this Issue

- Power Electronics ... 2
- Tête-à-Tête ... 3
- Junction Bipolar ... 4
- Chalk n Blackboard ... 5
- LED ... 6
- Byte This! ... 6
- Illuminati ... 7
- Know Thy Turf ... 7
- Photonic Crystals ... 8
- Check 'em Out! ... 9
- Spectrum ... 9
- Crossword ... 10
- Impressions ... 10
- loonEEy Toons ... 10

### The Team

**Chief Executive Editor**  
 Harpreet Singh

**Chief Editors**  
 Shriram Shivaraman  
 Sandeep Sangameswaran

#### CORE GROUP MEMBERS

Abhijeet Paul, Aneesh Nainani,  
 Sandhya Hegde, Lalit Goel, Vivek  
 Mishra, Anurag Singla, Gaurav  
 Mittal, Anshu Jain, Nishant Patni

*We shall not cease from exploration  
 And the end of all our exploring  
 Will be to arrive where we started  
 And know the place for the first time.*

-- T.S. Eliot

Technology is the cradle of civilization. In the era of super competition and leapfrogging scientific breakthroughs, it is invariably the fast and the steady who remain in the race, if not win it. And as the largest democracy of the world, India has a lot to say in the manner our planet is being led into the realms of sophistication. Be it the pure sciences or their applied cousins, India has been long known to produce many of the best men in these areas. It would not be an overstatement to say that the IITs of our nation form the crux of a technologically proactive factory continuously churning out world beaters.

And it is a matter of immense pride that IIT Bombay leads from the front in this aspect.

The right to speech of so potent a workforce cannot be suppressed. In fact, it is imperative that every technological vocation be given a voice to express its thoughts and concerns to the world. The case is no different with our very own Electrical Engineering Department here. The pages of this newsletter are not mere experiments in ink but are formed from the finest chords of technical harmony. Every scintillating piece of technology being developed in the department has an intense and melodious blend of dedicated and tireless co-operation among a lot of brilliant individuals who remain in the background. Thus, it would be highly appropriate to say that it is this very 'Background Hum' which has sustained our department through the decades and taken it to the glorious heights where it reigns with its entire splendor today.

Some of you would be aware of the existence of a newsletter with the same name till not so long ago. It got discontinued due to some unfortunate reasons. When we set out a few weeks ago, to bring back the forgotten glory of this mouthpiece, all of us were wonderstruck by the vision behind the name. Added to this was the immense apprehension as to whether we would be able to do justice to this vision as well as to our department. The realization of the enormity of our task and

the heavy burden of responsibility that was saddled upon us motivated us to form a dedicated team with a common goal. A lot of planning and effort has gone into bringing out this first issue of this newsletter. There have been a lot of ideas pouring in from all quarters as to the way this mouthpiece should be given form. We believe that we have done our best to include the best of all worlds in bringing out this issue. We have proposed to keep a definitive underlying theme for many of the articles included. This has been done with a vision of continuing along similar lines in the future issues with changes being incorporated as and when desirable. The comments and criticism of the interested reader are awaited eagerly by the editorial team.

In addition to the copious amounts of fun and frolic that you would expect

presenting some little-known but hot topic to the public with just enough technical details so as not to sound too much like popular science. ASIC or "Avant-garde Singular Idea Contest" is aimed to bring out original thinking and creative solutions from the students, encouraging them to think out-of-the-box. Exciting cash prizes have been proposed for the winning entries of these competitions.

The efforts undertaken by the entire supporting team for "Background Hum" as well as the professors who gave their valuable support and contributions are commendable. The editorial team wishes to express heartfelt gratitude to all the core group members involved in bringing out this inaugural issue of this newsletter. Special thanks are also due to the Department Feedback Committee for mooted this

idea and also to EESA. The editors are also indebted to Prof. Harish Pillai,

Prof. V. Ramgopal Rao, Prof. B.G. Fernandes, Prof. A.M. Kulkarni and Prof. A. Karandikar. Thanks are due to Sudhanshu and Adnan also. The start has been made and the first step has been taken. Let us march ahead steadfast with the aim of converting this small step into a giant leap towards the glory of the EE department.

## From the Editors' Desk

in any issue, the following articles are proposed to be regular features in the newsletter. The first of these is 'Junction Bipolar', a debate piece, which essentially explores and brings to light the two sides of an issue of relevance and general interest. Another regular article is 'Know Thy Turf' which aims to put some lesser used lab in the department under the spotlight and create awareness about the many facilities available there. 'Chalk and Blackboard' presents a rendezvous with a Professor. The idea behind this is to enable the faculty to express their views on the present scenario in the department and make the students aware of the faculties' expectations. There are also articles featuring successful alumni of the department and smart electrical engineers who have made a difference to this world. A feature story on some issue of technical interest is also included. Articles on some of the core areas of research in this department such as Power, Control Systems, and Communications etc. with valuable contributions from the faculty are proposed to form regular features of this newsletter so as to expose students to the various research competencies of our department. Besides, contests like LED and ASIC have been introduced with a view to enthuse students to explore various aspects of EE not taught in the classrooms. LED or "Let Enlightenment Dawn" is all about

### FEEDBACK

We would love to hear from you. Please send in your valuable comments and suggestions to [bh@ee.iitb.ac.in](mailto:bh@ee.iitb.ac.in)

Visit us at:  
[www.ee.iitb.ac.in/backgroundhum](http://www.ee.iitb.ac.in/backgroundhum)

**Department G.Sec.**  
 Harshad Kasture

#### EESA Council

**EESA G.Sec.**  
 Aneesh Nainani

**Joint Secretaries**  
 Gaurav Mittal  
 Nishant Patni

**P.G. Nominee**  
 Nisarg Shah

A diode bridge rectifier in an adapter used to power a radio scarcely handles power of few tens of watts. Can you imagine a rectifier system rated at 2,000,000,000W? Before we answer a counter question about why we need to have such a large rectifier system, let us tell you that such systems have been engineered in practice. For example, one such huge rectifier, which uses thyristors, converts power generated in coal rich Orissa (using AC synchronous generators rated at 500,000,000W) from high voltage AC (400kV rms) to DC ( $\pm 500$ kV) and transmits it over a distance of 1350km to the power hungry Karnataka. At the other end an inverter changes it back to AC. Wait a minute, haven't we been told that AC systems super ceded DC systems more than a century ago because of the ability to step up AC voltages for efficient transmission? Then why has DC made a comeback - at least in some applications? The answer lies in the physical characteristics of transmission lines.

## Problems with Long Distance AC Transmission:

We all know that electromagnetic phenomena are governed by Maxwell's equations. As a consequence, it turns out that a transmission line can be modelled as a distributed circuit of infinitesimal inductive and capacitive elements as shown below:

This causes some unusual effects, especially when line lengths exceed a few hundred kilometers and AC is used. If power flows in a long distance AC line are lesser than a certain value known as the characteristic loading, then over voltages are caused. This may cause dielectric breakdown of air around a conductor (flashovers). On the other hand voltages may sag if loading is too high.

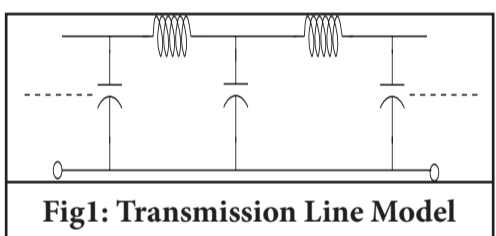

Fig1: Transmission Line Model

Another important problem with

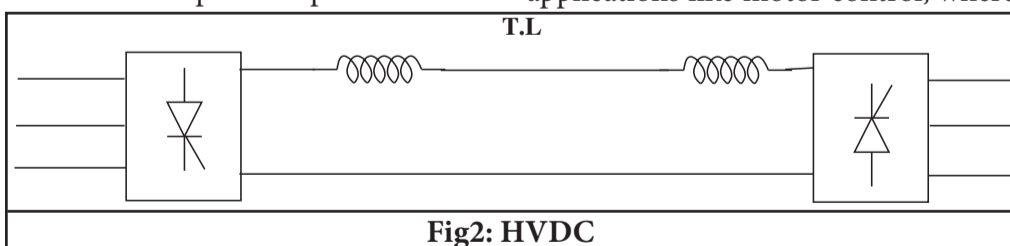

Fig2: HVDC

AC transmission is that one cannot operate a system with synchronous generators running at different electrical frequencies, because it causes pulsations in power flows and voltages.

Thus, if two generators are connected via an AC transmission path, then they have to run

# POWER ELECTRONICS for Multi Mega Watt Applications

Prof B.G. Fernandes and Prof A.M. Kulkarni

in synchronism. (Do you know, that at present a synchronous generator at the generating station at Trombay, runs in synchronism with a generator in Arunanchal Pradesh?) However, synchronous generators connected via long AC lines are susceptible to loss of synchronism due to large phase angular differences in AC voltages across the line. If generators in an interconnected system lose synchronism, they are electrically separated into islands. Failure to do so in a short time may result in cascade tripping of equipment and even a complete blackout in the grid.

Interestingly, power electronics can be used to solve these problems. This

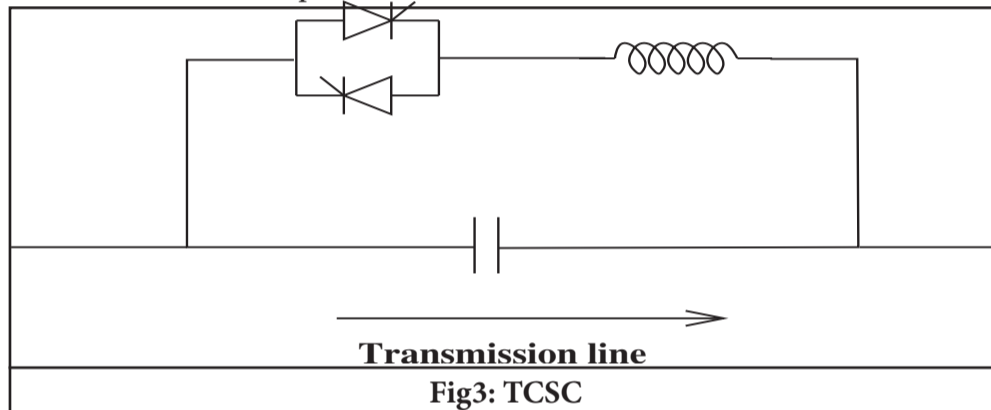

Fig3: TCSC

has been made possible by the advent of high power semiconductor devices.

## The Advent of High Power Electronics

The Nobel prize winning discovery of a transistor and subsequent developments in signal electronics eclipsed the rather modest advent of a four layer semiconductor device called a thyristor in 1958. This spurred a second, but quieter revolution called power electronics. Power Electronics used semiconductor devices as switching elements to control power flow much like a valve controlling flow in a pipe. These devices were operated in two extreme states, saturation and cut-off, from considerations of efficiency. This heralded a revolution in applications like motor control, where

these options allowed efficiency improvement and reduction in size over conventional methods. Power Electronics has found applications ranging from household applications like a fan regulator to spacecraft power supplies. The devices available today can block large voltages (10kV) and allow for large current ratings (6kA) when switched on. At the high device rating

end, we have Thyristors, Gate Turn off Thyristors and Insulated Gate Bipolar Transistors. At the lower power range, devices like MOSFETs are used which are capable of switching at very high frequencies (around 500 kHz).

## Application to Power Systems

Capacitive and inductive effects in transmission lines are not seen in steady state for DC transmission. Therefore, DC transmission becomes attractive for long distance transmission. A typical scheme for DC transmission uses a transformer to step up the AC voltages and then rectifies them. High Voltage DC trans-

mission is done and the voltage at the other end is inverted back to AC.

Instead of outright conversion to DC, one may even modify the characteristics of a transmission line by connecting variable capacitors and inductors in series or shunt, to suit various operating conditions. Variation is made possible by power electronics.

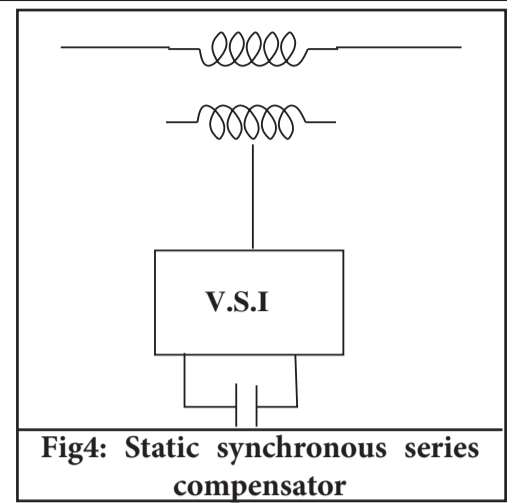

Fig4: Static synchronous series compensator

Instead of outright conversion to DC, one may even modify the characteristics of a transmission line by connecting variable capacitors and inductors in series or shunt, to suit various operating conditions. Variation is made possible by power electronics. An other device uses a voltage source inverter (VSI) to inject variable voltage into a transmission line. Considering the large ratings, the challenges in engineering these equipment are immense. The technology in some cases (like HVDC) is well matured, while in other cases, only a few prototypes are in operation.

## Conclusions

Power Electronics is likely to play an even bigger role in the basic infrastructure of our country. Some of the equipments which have been described in this article have been implemented in our country, and many more are planned. It will allow greater, flexible and controlled power exchange between various regions. Before we sign off, it will be instructive to have a look at the High Power Electronics installations in India at the present time.





**W**hat does every IITian aspire for? Success! We present to you a success-story from IITB, Raghunath S Iyer, Director of Systems Integration at Nevis Networks Inc., Pune. Raghu Iyer obtained his Bachelor's degree in Electrical Engineering from IIT Bombay in 1981. Further, he pursued his Masters degree in the Department of Computer Science and Engineering at IIT Bombay. Excerpts from a telephonic interview with him.

**How would you describe yourself?**

I would describe myself as someone tempered by experience, someone passionate about technology, astronomy, photography, traveling and music.

**What guiding principles do you adhere to in life?**

Think positive; attitude makes a lot of difference, be organized and disciplined. Life will be full of difficulties and challenges. You don't always get what you want. The negative way of looking at things is that if something is not to your liking, you try to get out of it. Another way to look is to take up the new thing as a challenge and try to do it. This attitude will make you more adaptable and it will give you the skills that you can apply to other places. The environment around you is larger than what you are. You can do some amount of picking and choosing. But you can't afford to make it too narrow else you won't be able to learn something substantial. Take ups and downs in the positive spirit and you'll have a good time.

**Tell us about some significant memories of IITB that you hold.**

The entire experience is worth reliving. The IITs have a culture of transparency that is not found elsewhere in this continent. The facilities are phenomenal. Again, as I said, you could look at it negatively and say that IITs are not like MIT or Stanford. I have met several students coming from smaller and bigger colleges in the US. Believe me, the poorer colleges there are far too behind. IITs are associated with industry; thus students get a chance of working in real-life projects. You could end up doing a BTP closely related to industry or some current problem. Such an association is rare in the US. In fact, you can count them on the fingertips. Non-academic activities like sports, hobbies-development or the cultural events are also encouraged a lot in IIT. If somebody today says, 'Ok Raghu, we'll take care of your living for the next five years. What would you like to do?' Then, I would go back to IIT and enjoy life there. There you work hard,

you play hard and you enjoy life. You can't beat the system there. It is positive energy all the time.

**Anything freaky, crazy that you did at campus?**

We used to have our share of ragging and fun. Nothing extremist, I mean if you are thinking about people getting bumped or drunk, I don't feel that was crazy. Maybe I have grown too old to think of it as crazy anymore. It sounds funny at the time you did it but maybe it is not so funny now. I mean a dare could be, you don't know how to swim and your friend dares you to swim across Vihar Lake. Or you are asked to go to the ladies hostel and ask somebody out for dinner. I don't know if these are dares or not. These are aspects of growing up. At some point, it appears to be a dare; at some other time, you feel like what's the big deal about it. You grow over it.

**“The environment around you is larger than what you are. You can do some amount of picking and choosing. But you cannot afford to make it too narrow else you will not be able to learn something substantial.”**

**Tell us a bit about your hobbies.**

I started trekking at IITB. There used to be a monsoon trek. Given an opportunity, we would like to take a Saturday or a Sunday morning and go out. Photography was something which took my fancy when I was doing my Masters. I still have the camera I bought when I was on the campus. Besides, I am a music freak and have recordings of artists like Pandit Hari Prasad Chaurasia, Ustaaad Zakir Hussain, Shiv Kumar Sharma, Bhimsen Joshi etc, who came and performed during my time at IIT. I also enjoy western music, especially Pink Floyd and Dire Straits. I also appreciate Indian classical music and have learnt Veena for more than ten years.

**Any reminiscences of professors, something particularly interesting that you would like to share with us?**

Oh, there are many of them. In fact, even today, I quote them. The toughest often turn out to be the best. We had a Prof. who taught us machines and electromagnetism which is difficult to visualize. You had to see students in other colleges to know the real value of his lectures. We had Prof. Kamath who taught us twice to pull us out of our bad grades and both were interesting in their own way. Then there was the infinitely patient Dr. K.C. Mukherjee from the communications department. He used to set such a paper

# Tête-à-Tête

that if you managed to get a CC, you would feel good about it. Then, I did a lot of projects with Prof. Rao of the CS department. He created a very fertile environment for you to blossom. I remember fondly Prof. Isaac, the then HOD of CS department. In the EE department, we had Prof. Agashe and Prof. Narayan, very good teachers who taught us to get interested in class.

**Do you still keep in touch with the friends you made in IIT?**

Yes, it is one of the best networks in the world that you can have. I can recollect the names of 50% people of my batch. I am in touch with 20%. We mostly know where each one is. The batch-network helps in later life. You then know its value.

**What prompted you to take up a job and not pursue a PhD?**

Even pursuing masters was a big question mark. If you are looking for an academic career, it is doctoral research that you should be doing. But if you want to pursue a job in the industry, I think a Masters is adequate; you better focus on building a career. If you continue to do doctoral work and then join a job, the value of the doctoral work is not so high because the industry doesn't want solutions to problems that might arise within the next 50 years; it wants so-

**“I like to solve problems but I like to see them solved today and see customers benefiting from it. I could solve an abstract problem in any domain and if its impact cannot be felt today, it doesn't give me as much a pleasure as solving one that would impact people within the next 5 yrs.”**

lutions to problems that are imminent i.e. might arise within the next 2 to 3 yrs. I like to solve problems but I like to see them solved today and see customers benefiting from it. I could solve an abstract problem in any domain and if its impact cannot be felt today, it doesn't give me as much a pleasure as solving one that would impact people within the next 5 yrs.

**Tell us how you started your career and what paths it has taken.**

While working under Prof. Rao, I had to play the parallel role of a project manager and an M.Tech student. We

built I/O controllers, firmware and hardware. While doing this, Prof Rao with his engagement in industry got a project from Godrej. I naturally got involved in it. In 1993-1994, this division began developing electronics resulting in products such as dot-matrix printers, electronic typewriter and later, on their own. Customer problems forced us to go back and improve engineering. The division grew from 20-25 to 100. Times were changing. The division had to go through a transformation. One of the fallouts was that part of the division spun out as a different company. I opted to work with the spun out part. I headed one of the three subdivisions. The company started seeking overseas customers. I had to go to California. After a year there, we realized we should do something in the products world. We came upon a technology called Classification which would help networking devices to traffic engineering well which could boost their performance speed to gigabytes. It became successful. I now decided to come back. Then I joined Nevis Networks.

**So, how did you decide about pursuing networking?**

In the earlier part of my career, it was mostly hardware and firmware. Geometric software was the place where I did pure software. I was the only guy in the team who knew hardware. So my second role was that I became the IT administrator, putting machines on everyone's desktop. I learnt networking that way.

**What kind of experience did you have at IIT that made you qualify your first job?**

The projects with Dr. Rao. Again, I keep on repeating-do what you have in your hand and do it well. That's the only weapon you have with you to convince somebody that you are a good candidate. If you screw up your academics, you have lost it. Academics are nothing but a large assignment. It's an opportunity you are given to learn something and do something with it.

**What's the secret of your success and what principles do you hold as a director of Nevis Networks?**

I am enjoying life. I can't say beyond that. There's a big success here. The secret is that there is no secret. Just be passionate. Don't give your 100%; give your 200%.

Ashutosh Gore obtained his B.Tech. degree from EE, IITB in 1998, and then studied and worked in USA for 4 years. He is currently in 3rd year of his Ph.D. in the Department of Electrical Engineering, IITB.

## JUNCTION

### Bipolar

Knowledge is power and every ambitious student who wants to excel as a technocrat, researcher or professor should definitely aim for a doctoral degree from a reputed university. In a nutshell, a Ph.D. student or research scholar (RS) reads research papers in his chosen field, formulates a new problem, obtains theoretical and/or experimental results, publishes papers in international peer-reviewed conferences, has his thesis reviewed by four professors (one from abroad) and finally defends his thesis. It is very important to realize why one wants to do a Ph.D. Some students are sure about this during their B.Tech. or M.Tech. years, while others spend some time in industry, realize what the "real world" is and then come back. Either way, life is different as a Ph.D. student. One has to be highly self-motivated, think independently and minimize "garbage collection activities". The journey is far more important than the destination. During the Ph.D. program, one's perspective to problem-solving changes by orders of magnitude.

At the outset, let me emphasize that it is wiser to do a Ph.D. from IIT/IISc than a "non-top 25" university in USA. Let me now focus on the merits of pursuing a Ph.D. in IITB, esp. in the EE dept. IITB is one of the few technological universities in the world which has departments in all the pure sciences, all the important branches of engineering and more recently, even schools of management and information technology. There is scope for interdisciplinary work - for example, in nanoelectronics. The EE dept. is one of the few in the world which has excellent and cooperative faculty in communications engineering, microelectronics, power electronics and power systems, controls and computing, and electronic systems. Other hallmarks of a good Ph.D. program are "library" and "labs". Our central library subscribes to all IEEE and Elsevier journals (since 1960) and stocks the proceedings of important conferences and the best books in any field. In fact, if a book (foreign edition) is required for your research and is currently unavailable, your advisor can request the library to acquire it - this process takes at most 3 weeks. Most of the labs in

the department have been renovated, have ample computational facilities/engineering equipment

and are air-conditioned. While it is true that we don't have state-of-the-art equipment in few labs, this is mainly due to limited funding from the Indian industry. However, the symbiosis between academia and industry in India has been growing rapidly in recent years - this will definitely go a long way in making IITB a world-class research institution. Consider the fact that we have done very well for an institution which is not even 50 years old, while MIT is around 140 years old.

Let me now take a slight detour and comment on the quality of research at IITB. The hallmark of any highly successful company or institution is its ability to attract and retain talent. It is high time to implement certain measures to make IIT a world-class post-graduate institution. In comparison with a top-25 university in the USA, what IITB lacks in is not the quality but the number of M.Tech. and Ph.D. students. A larger research group leads to more motivation, more technical discussions,

better critique and consequently higher quality research output. IITB should also introduce post-doctoral fellowships to attract recent Ph.D.'s from IITs/IISc and abroad. Post-doctoral fellows can supervise the progress of current Ph.D. students and can also be inducted as faculty in due course of time. This can only be achieved with increased funding from the industry and the central govt.

In a Western country, a Ph.D. student has to live in a 2-bedroom apartment with 3 other students (which can be hassling), cook his own food and own (thus maintain) a car. If you compare that to IITB where one can stay in H12, eat good mess food and cycle in the campus, a lot of time and energy can be saved. The winters in western countries are usually harsh and outdoor physical activity is at a minimum - compare that to IITB in which the winter months are the best for jogging! To sum it up, what matters in a Ph.D. is what and not where. That is, the appraisal of Ph.D. work depends on the individual's publications and thesis, and not on the institution which granted him the degree. A Ph.D. student is motivated by the desire to learn and assimilates the knowledge in his field both in breadth (while hunting for a topic) and in depth (by solving his newly formulated problem). The academically-inclined reader is requested to carefully weigh his options and eventually consider joining his alma mater for the Ph.D. program.

Dheeraj Prasad Singaraju a.k.a Golu, obtained his Bachelor's degree from EE, IITB in 2004. He is currently pursuing his Masters and Ph.D. in ECE Dept. at University of Maryland, Baltimore, USA.

Come 7th semester, there is a certain group of students who decide that they would like to pursue further studies and start researching the various places they could go for this purpose. A list is finally prepared and with the extreme rare case, it is not surprising to find any one of the IITs featuring in the list. This makes me ponder over whether the question of the hour is really 'Do students want to pursue PhDs abroad?' or 'Do they NOT want to pursue a PhD in an IIT?' Before I begin my answer to this question, I would like to make a disclaimer that some sentences might hurt the sentiments of some people (though definitely not intended), but then this is what I feel and need not be the general opinion.

### Ph.D : In India or Abroad?

One may reason that a person might not like to continue his/her PhD at IIT is that he/she, having already spent 4 years in undergrad primarily, needs a change of environment and would get more exposure by a change of institution. But then, that raises the question as to why not shift to another IIT to pursue a PhD.? What is it that places the foreign universities high above the IITs for graduate studies? I think that all of us will definitely agree that there is this part of us that wants to travel new places and explore new frontiers. Other than this, what are the factors that make us apply abroad? Better advisors? Better facilities?

It is very easy to see that the issue is not regarding advisors as we ourselves have seen that the professors at IIT are definitely up there with the top. So, this brings us to whether the issue is regarding facilities. Consider a person like me working in the area of computer vision. All I need is a computer and a camera which are readily available in the SPANN lab. So, am I justified in saying that I have come to the US for better facilities? In fact, I believe that the microfabrication lab at IITB is as equipped (if not more) as the fab labs in most of the top univs in US. In short, it would only be right to say that IITB has great facilities for most of the areas of research. So, what is it really that makes us migrate to foreign univs?

One area where foreign universities

score over IIT I feel is the exposure. Since, one would be working with (probably the best) students from all over the world, one gets exposure to different styles of teaching, different trains of thought and temperaments which is very important for a successful PhD. I also think that it would be right to say that the professors in IIT are not as 'active' in research as in the universities abroad. Then again this is due to several reasons that professors at IIT tend to give greater importance to teaching while it is not surprising to find a professor (in the US atleast, I cannot vouch for the other places) not teaching any course. The fact that these professors can channel all their resources towards research is definitely a positive factor.

Having spoken about the factors favouring the foreign universities, I think it is important to mention that a major deterrent for a PhD in IIT is that there is this general feeling (urban legend?) that the PhD program at IIT isn't good. Well, if I am given the luxury to call us IIT undergrads the 'cream of the crop', how can one expect great research to be done at IIT when the cream is doing research elsewhere? This statement might sound very high handed but I do feel that there is a certain amount of truth in it. It is all a vicious circle. The quality of research will definitely tend to improve if the smarter students continued in IIT for their PhDs, but the thing that would probably scare them is the prevalent quality of research. One way we can possibly improve the situation in IITs in the future is to fund research in IIT. The biggest advantage that the US universities have over IITs is that they have institutions like National Institute of Health (NIH), National Science Foundation (NSF) etc. to fund projects. If the IIT's can imitate such funding institutions by diverting part of the alumni funds into projects we can get better research done. Also, incentives can be given by funding the students to go to international conferences to meet other groups working in the same area. Such an effort can attract B.Tech/Dual students as well to do good research and get publications out with the incentive that they can go to conferences abroad. This will not only add to the student's CV but also increase competition among students, thus increasing the standard of research in IIT.

In the last 8 months I can say that I have had a very satisfying experience in my university and if asked to make a closing statement I would say that one should definitely consider pursuing a PhD abroad. However I also do believe that we should return to India after completing our PhDs (and probably teaching/working for a few years), but then I think that is a topic of discussion for another issue ;)

**P**rof. Abhay Karandikar is a faculty in the Communications Engineering division of our Department. He joined EE, IITB in 1997. Very recently, he has launched a start-up Eisodus Networks. Excerpts from an interview conducted by Abhijeet Paul:

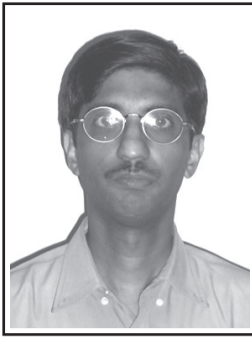

*in the department specifically under you?*

I have worked with Texas Instruments (TI), Cirrus Logic, Sasken Communication and SwitchOn Networks. Also, I have done consultancy work for industries like L&T Infotech and Tata Infotech. Besides, I have had projects from agencies like DST, MHRD etc.

**We have heard a lot about your start-up Eisodus Networks. What role do EE students play in this?**

We do not have any students working for our startup. Currently, we have full time employees, most of them EE graduates from IITB. Basically, ours is a purely technology development company and not a company involved in developing some application product. We are focusing on developing technologies in the area of broadband In-

munication networking jobs, where people with expertise in electrical engineering and having communication background work on projects. In that sense, students and EE graduates who

**“For the coming few years the UG program may continue to be emphasized unless we upgrade other institutions (RECs, NITs) to that level. Then, we can transform to a pure research institute. The ideal thing would be for IITs to become pure research institutes and have the NITs for UGs.”**

at IITB, but entrepreneurship is also gaining government level recognition in terms of programmes for promoting entrepreneurship at IITs and translating technical ideas developed in IITs into successful commercial ventures.

**What difference do you see in the research aptitude and projects of the students today and 10 years back?**

Personally, I feel students have always been the same. However, some faculty members do feel that there is decline in the standard of students. There may be some element of truth in it. One thing is that decline had happened primarily due to the societal changes. The changes in societal values are bound to affect all walks of life. Second thing is that JEE is highly competitive. People slog in their 12th Std., as a result, when they come to the first yr, they are completely exhausted. So they don't have enough energy left in their 4th and final year to contribute. Third reason has something to do with the student-faculty interaction. It is not happening on a regular basis as it could, probably due to the increase in the number of students per faculty (at-least in departments like EE). However, I feel that given the students' potential they can do a lot better than what they could do some 20 yrs back because the infrastructural facilities, interaction with the industry and number of projects have definitely increased. Student should exploit these to their advantage and show more interest in research.

**What prompted you to choose communications engineering as your field of interest? Tell me about your past academic background.**

I had developed my interest in Communication Engg during undergraduate years only. I completed my Ph.D. from IIT Kanpur. After that, I worked for CDAC in PARAM 9000 super-computing group.

**What are your major areas of interest in communications engineering?**

My areas of interest are currently communication networks and wireless & mobile communication. In communication networks, the main emphasis is on QoS, resource reservation and control problems. In Wireless communication, focus is on QoS in wireless networks - both packet radio networks as well as CDMA based mobile communication.

**What are the projects that are currently being guided by you?**

Most of the current student projects are in the areas of wireless communication. In the past we have worked on QoS in Internet, packet scheduling algorithms, resource reservation schemes, admission control and traffic modeling.

**Which industries support research**

## CHALK Blackboard

**“Three main things are needed for a startup: a product idea having some value proposition to the customer, a competent team and resources in terms of funds and other requirements.”**

ternet access; more specifically we are developing Ethernet based broadband access product which will eventually conform to the new emerging standards of Metro Ethernet (ME) forum. There exists a team for hardware designing, a team for embedded software and a team for network management solutions (NMS). These are core com-

are interested to work in core communication and networking are required. Very few core Indian companies like this exist. A few prominent ones are Tejas networks and companies incubated by IITM.

**Many ideas come up in our EE department, however very few evolve as startups. According to you, what are the main ingredients for a startup?**

Three main things are needed for a startup; one, you should have a product idea which should have some value proposition to the customer. It cannot be just a research idea or research product. Second thing is the competence of the team. Fortunately, we have very competent people. I would say that some of the best M.Tech people from IIT Bombay are in our company. The third thing that you need is resources in terms of funds and other things.

**What do you think about a department-supported startup program?**

Previously IIT Bombay had a KReSIT business incubator. Now it has a formalized body called SINE (Society for Innovation and Entrepreneurship). The institute support is coming from SINE and IITB directly. All a department can do is facilitating as they have done in my case: I have been on leave for one year. SINE plays a much needed supportive role for startups. Earlier the incubator was only for communications and information technology. But now it has been extended to all branches of engineering. Apart from infrastructure, it is also giving some kind of seed loans for incubatee companies. Not just

**How can this scenario be changed?**

I do feel that for the coming few years the UG program may continue to be emphasized unless we upgrade other institutions (RECs, NITs) to that level. Then, we can transform to a pure research institute. The ideal thing would be for IITs to become pure research institutes and have the NITs for UGs. But the only question is whether NITs can deliver the quality that IITs are delivering.

**According to you what's the next big thing in the field of networking?**

As you know Internet has transformed the entire world and the way we live today. In some sense, a new world order has been set. The next big thing is going to be a networking infrastructure that enables anytime, anywhere computing and communication with robust security. This is going to fuel research in low cost, energy constrained wireless devices, a framework of security and faster and reliable transfer over wireless. There are still many challenges that need to be addressed in the area of wireless networking.

Department Placement Statistics 2005

Total Number of Offers : 141

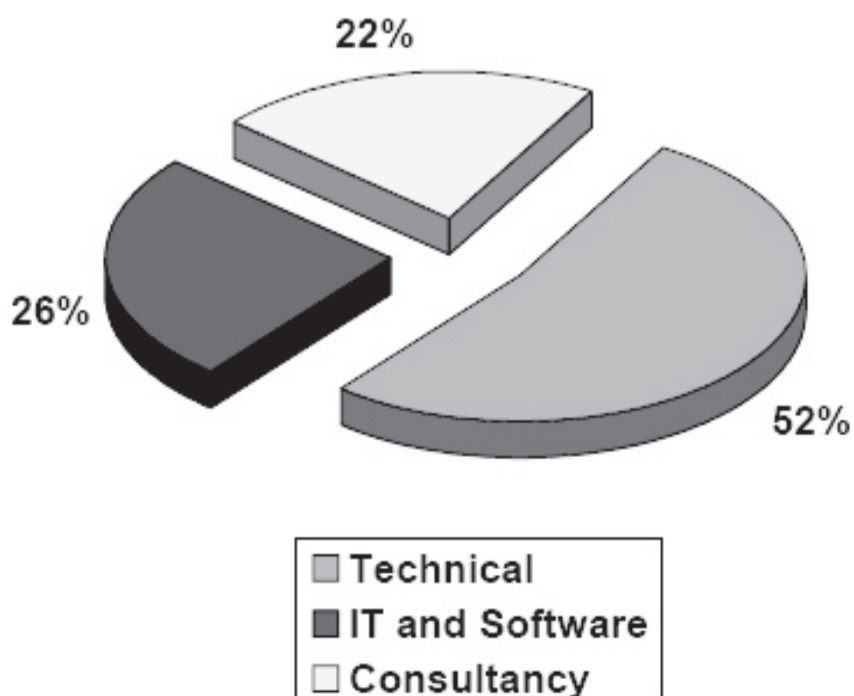

**I** don't know how to do this on a small scale in a practical way, but I do know that computing machines are very large; they fill rooms. Why can't we make them very small, make them of little wires, little elements and by little, I mean little. For instance, the wires should be 10 or 100 atoms in diameter, and the circuits should be a few thousand angstroms across... there is plenty of room to make them smaller. There is nothing that I can see in the physical laws that says the computer elements cannot be made enormously smaller than they are now. In fact, there may be certain advantages.

– Richard Feynman (1959)

Electronic technology has rapidly evolved during the past decades. The emphasis is to make better, faster and smaller electronic devices for application in modern life. The contemporary advanced silicon chip can store 16 million bits of information within an area less than 1 cm<sup>2</sup>. Pentium 4 chip contains more than 50 million transistors. However, there is a practical limit to the scaling. It will soon reach physical and technical limits, inspiring the development of new technologies. Molecular Electronics is being seen as potential stakeholder for the same.

Molecular electronics can be defined as technology utilizing single molecules, small groups of molecules, carbon nanotubes, or nanoscale metallic or semiconductor wires to perform electronic functions. Some have de-

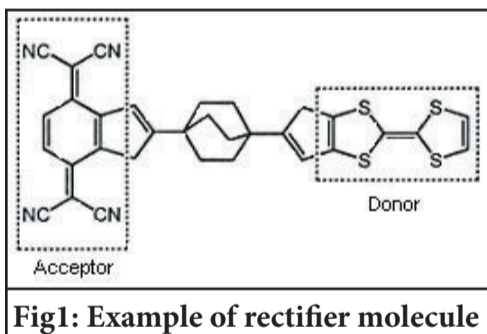

**Fig1: Example of rectifier molecule**

defined it as technologies utilizing only single molecules, but this definition is far too limiting. From the broader definition, it can be suggested that any device utilizing molecular properties is a molecular electronic device.

The first theoretical and experimen-

## Hydrogen - the next fuel for laptops?

A New Jersey firm, Millennium Cell, is developing an 8 hr hydrogen fueled cell battery. The battery works by initially storing sodium borohydride as a solution in the cartridge. This solution passes through a fuel pump and



moves into a catalyst chamber, which triggers a reaction. The reaction causes hydrogen to

tal efforts in the molecular electronics arena began as early as 1970s with the work of Aviram and Ratner [1], proposing a single molecular rectifier. They proposed that, to show rectification, an organic molecule should have roughly the properties of a p-n junction. By the use of aromatic systems, it is possible to increase or decrease the pi electron density within the organic molecule, and therefore

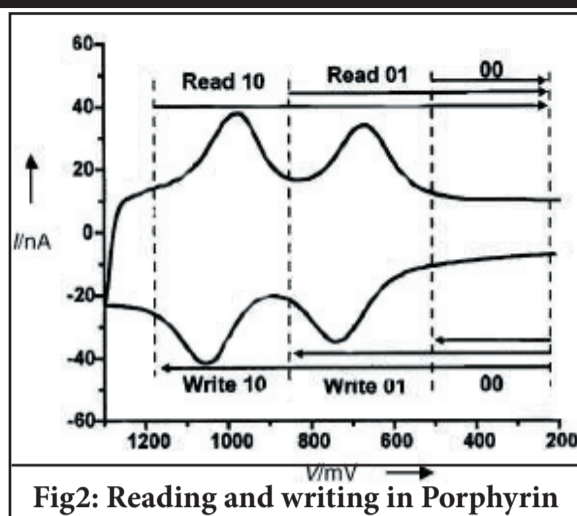

**Fig2: Reading and writing in Porphyrin**

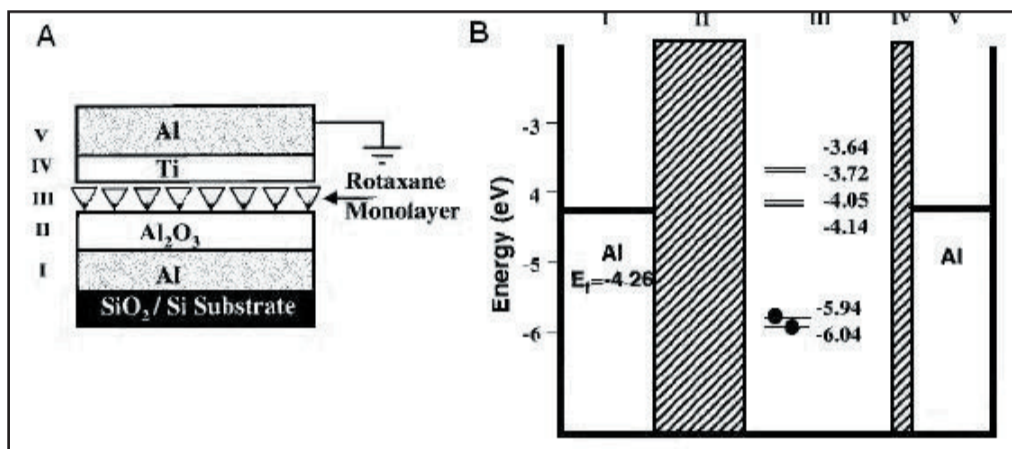

**Fig3: Structure(A) and Energy diagram(B) of the switch. Oxidation states are marked with dotted circles. Diagonally striped areas are tunneling barriers. Thick barrier is Al<sub>2</sub>O<sub>3</sub> passivating layer & thin one is Ti-rotaxane interface.**

create relatively electron poor(p-type) or electron rich(n-type) molecule subunits. Fig. 1 shows such a molecule. The part of molecule joining the donor and acceptor, has sigma bonds, providing internal tunneling barrier from donor to acceptor.

The rectification behaviour can be explained in detail by examining energy-level diagrams for the system. The difference in positions of Highest occupied molecular orbital(HOMO) and Lowest unoccupied molecular orbital (LUMO) of acceptor and donor groups gives the rectification behaviour.

Information storage is an important part of the electronic world today. Similarly, nobody can think of moving to the world of molecular electronics without molecular memories. The basic paradigm for electronic information storage is retention of charge in a capacitor. So the most straight forward

separate from the liquid fuel. The hydrogen then moves to the fuel cell in the laptop, where it mixes with oxygen. Oxygen enters the laptop through a series of perforated holes in the laptop

## Byte This!

casing. This reaction of hydrogen and oxygen creates electricity.

## Roving camera controlled by Bluetooth

Sony Ericsson has demonstrated a

robustly and reversibly oxidized with up to two holes stored as illustrated in I-V characteristics of the porphyrin (Fig. 2). (Note that porphyrins are of many kinds and this is valid for only some special kind of porphyrins.) The two waves correspond to the formation of the monocation and dication. Charge is stored (written) to the porphyrin molecules via application of a voltage step, that is set at an oxidizing potential.

Switches are the basic elements of control in any electronic architecture -by its very function it either allows current to flow or not. There are many examples of proposed molecular and atomic switches, which use a variety of mechanisms of operations. The development of a molecular switch is perhaps the single most important element in developing molecular replacements for conventional inte-

Bluetooth controlled camera on wheels which can be controlled by the joystick or keypad on a mobile phone. The Motion Cam ROB-1 can rove up to a distance of 50m from the user while streaming video to the phone's display and individual photos can be taken. The device having an onboard memory and measuring 110mm diameter has three wheels and can move forwards, backwards, look around corners, pivot on the spot and tilt the camera.

Compiled by Gaurav Mittal. He can be contacted at gmittal@ee.iitb.ac.in

grated circuits. There have been several significant suggestions of complex switching behaviours, which include use of arrays of switches to implement logic operations and the use of two-terminal resonant tunneling devices to do the job of switching. A number of examples of molecular switching have been proposed based on quantum effects; single molecules, carbon nanotubes and quantum dots or nanoparticles have all been found under the right circumstances, to display some of these quantum effects.

An electronically (singly) configurable junction that consists of a molecular monolayer and a tunneling barrier (redox active rotaxanes) sandwiched between metal wires is shown in figure 3. This junction can be used as a switch and several devices, fabricated in a linear array structure, could be used as electronically configurable wired logic gates. As roxatane molecule shows different energy level in normal and oxidized state, there are two states and the switches are irreversibly opened by applying oxidizing voltage across the device. Tunneling does not occur in oxidized state, hence oxidation opens the switch. The on and off currents differ by a substantial amount. [Fig. 4] Furthermore, these switches can be used to construct (once) programmable molecular logic arrays.

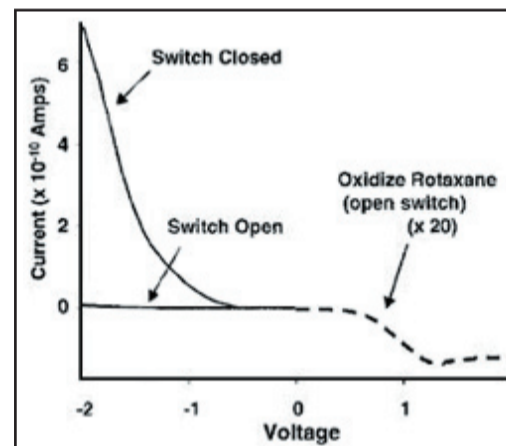

**Fig4: I-V characteristics of the switch**

There is a great promise to molecular electronics – electronics that is smaller, faster, more efficient and potentially more flexible than conventional electronics. Clearly, some visible, fundamental demonstrations have been made of molecular-scale electronic device behaviours. However, it's still a long way of experimentation and research before molecules will find their place in commercial electronics.

## References

- [1] A. Aviram and M. A. Ratner., *Chem. Phys. Lett.*, 29(2):277–283, Nov. 1974.
- [2] C.P.Collier et. al., *Science*, 285:391–393, July 1999.
- [3] Zhiming Lu, Amir A. Yasseri, Jonathan S. Lindsey, and David F. Bocian., *Science*, 302:1543–1545, Nov. 2003.

(All images courtesy IEEE papers)

Saurabh Goyal is 4th year DD(Microelectronics) student. He can be contacted at sg@ee.iitb.ac.in

## Illuminati Suhas Patil

“When I fully understood the power of Suhas’s software, it hit me like a ton of bricks that his design approach could be the basis for a new kind of Chip Company. I could see the opportunity to get complex chips out in just six months using system designers who didn’t require knowledge of silicon”, said Mike Hackworth, chairman of Cirrus Logic.

Hackworth joined hands with Dr. Suhas Patil to found Cirrus Logic. He wrote, in the same book that Cirrus Logic “rocketed to a billion-dollar-a-year rate faster than any other Silicon Valley semiconductor firm that ever made that climb”. Today Cirrus Logic Inc. is a leading manufacturer of advanced integrated circuits for multimedia, communication and mass storage in personal computers.

And the one idea behind this success was that of Dr. Suhas Patil. Hailed as one of the most erudite technopreneurs in Silicon Valley, he had a very humble beginning. He was just a child with a fascination for tinkering with objects, especially those around his house. His father had a side business of repairing radios. This gave him a lot of things to work on - wooden, metal and finally electronic. He remembers with fondness the Mechano set he played with.

During childhood he got very interested in chemistry. Since the lab at school wasn’t enough for him, he decided he should have one at home. So he started to ‘create’ a lab of his own. The Bunsen-burner needed gas, but there was no gas at home. So he read

enough to see how one could actually ‘manufacture’ gas. He came to solution - crack petrochemicals to create gas. He built an apparatus to take kerosene, crack it to make gas, so that he could have a Bunsen flame. A ‘ridiculous’ attempt in his own words, with an obvious result - the apparatus caught fire. Not satisfied, he tried to lift it once it caught fire and ended up burning his fingers.

Dr. Patil did B.Tech (Hons.) from IIT Kharagpur in 1965, Master of Science in electrical engineering from MIT in 1967 and Doctor of Science (EE) from MIT in 1970. From 1970 to 1975 he was Assistant Professor of EE at MIT where he also served as Assistant Director of Project MAC (Multi-Access Computer), the largest computer science laboratory in the US where time sharing system was developed. From 1975 to 1980, Dr. Patil was an Associate Professor of computer science at the University of Utah. Dr. Patil’s research here reached a stage where “either somebody had to adopt it and take it further”, he once told an interviewer. He further said, “But it was so different that industry didn’t want to pick it up. There was too much gap between what I was suggesting and what the normal practice was in the industry. So I couldn’t give it away!”

That somebody happened to be General Instrument Corporation. With that funding, Dr. Patil completed

work on software that automated VLSI design. The technology permitted even those not trained in silicon technologies to design integrated circuits in six months, a revolutionary step in 1980s. In 1981 Dr. Patil started Patil Systems Inc. based on his academic research. In 1984 he founded Cirrus Logic with Hackworth. Cirrus Logic has, since then, grown to be a major semiconductor company developing, manufacturing and marketing ICs for personal computers, communications and consumer electronics.

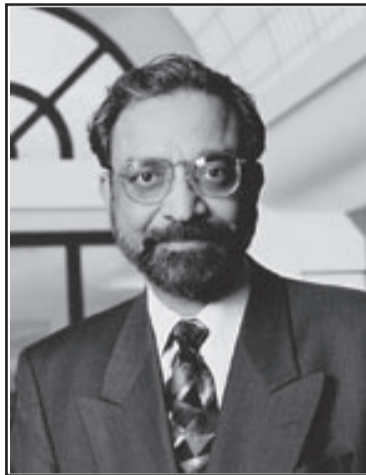

In 1992, Dr. Patil, together with other successful entrepreneurs and businessmen of Indian origin in the Silicon Valley, formed a non-profit organization called TiE (The Indus Entrepreneurs) to assist upcoming entrepreneurs in their endeavor. Dr. Patil was elected its first president and under his leadership TiE

became an effective and respected organization nurturing and mentoring entrepreneurs. Cybermedia, with their software for automatically fixing personal computers is one such example. In fact, Dr. Patil has personally been a mentor to Cybermedia and is a member of its Board of Directors.

He serves on the boards of many companies such as RightWorks and Aspirian Inc. He is also the chairman of Cradle Technologies, Tufan Inc., Navin Communications and Reez.com. He is also on the board of community organizations like the Asso-

ciation of Indians in America and is a member of the Board of Overseers of the Computer Museum.

In 1995, IIT Kharagpur conferred an Honorary Doctor of Science degree on Dr. Patil for his work in science and industry.

Dr. Patil has worked in the fields of computer architecture, parallel processing, mathematics for computer science, design methodology for VLSI circuits and integrated circuits design automation software. He has over 40 scientific papers covering these areas of research and has several patents in the fields of Integrated Circuits to his credit.

Dr. Patil feels his education has played a major role in his success. He feels a doctoral program is the perfect training if one wants to start a company. In his words, “You can finish your undergraduate degree by simply presenting what is very well learned in a very efficient manner. You go to the master’s thesis under very strong guidance. The doctoral thesis is all uncharted territory. And this is a very arduous, taxing process. At that point, you have to learn not only to do the science but also to cope with disappointment how to handle yourself as a person and how to pick yourself up even when something doesn’t work. Deal with the blues. And going through that human process, you learn a lot. It’s a pity that not many people understand this aspect.”

*The above success story was compiled by Lalit Goel. He can be contacted at lalitgoel@ee.iitb.ac.in.*

**T**he PCB lab, which received a facelift in the recent past, is one of the lesser known labs in the Department. Anurag Singla explores this rather obscure laboratory located in the Annex.

### Who are the people involved in the lab?

Prof P. C. Pandey is the Professor-in-charge. The technical staff, which includes Mr. Edward Misquitta, Mr. Vidyadhar, Mr. Kamble and Mr. R. S. Kedare, is responsible for managing the lab’s entire gamut of activities ranging from taking in application forms from students to delivering the final PCBs.

### What are the departmental bylaws/procedural guidelines regarding the lab usage?

PCB lab is the only lab in the EE department which can boast of a central facility, i.e., students from any department can make use of this infrastructure very easily. To take advantage of the services, a form available with the lab attendants needs to be duly filled in, signed by a Professor and submit-

## KNOW THY TURF

ted in the lab. Personal work is not catered to in the lab. However, jobs are accepted during Techfest period, but again, they need to be approved by a Professor. The services are free of cost and no GPBs (General Purpose Boards) are needed beforehand.

### How was the renovation of the PCB lab funded?

The facility was upgraded with grants from DST (Central Government Enterprise) in July 2002. The overall expenditure was about 1.6 million rupees. The expenses post-renovation are being borne solely by IITB.

### What new facilities have been introduced since renovation?



The most significant addition is the Rapid Prototyping PCB Fabrication setup. There are essentially three machines involved in this technique. The MiniContac II (LPKF -German made) is a galvanic through hole plating system. It executes the job of PTH (plated through-hole, i.e. metal plating on the wall of the hole) through electroplating. This process normally takes 2-2.5 hrs. The through-hole plating is an important design consideration for a double sided board, which can allow the fabrication of more complex boards while significantly reducing the number of vias. The through holes meet the highest requirements. The next machine down the order is the ProtoMat C60. This accomplishes

the part of drilling and milling which essentially involves boring holes and carving out the tracks. An extremely precise, reliable plotter head moves over the board area boring holes and carving tracks in a motion governed by a computer program. The computer interacts with the machine with a driver program called BoardMaster. Data required to drive the plotters is generated in-circuit CAM and is stored as files in GERBER format. The distance between two tracks is usually 0.2mm and diameter can be as small as 0.6mm. The circuits are usually prepared in conventionally available software like Eagle. The maximum size of PCBs that can be made is A4. For making PCBs of more than two layers, LPKF Multi-press II is used. It can make upto six layer PCBs in-house. This is achieved by subjecting the PCB to a pressurized (6 bar) oven with temperatures of the order of 250°C.

*(continued on Page 8)*

**I** was the second exasperating call that I had received. Yet another group of theorists were saying that my discovery did not work. That was distressing. I had spent three long years trying and discarding countless designs to arrive at what I thought was success, but if the theorists were right, I had to go back to the lab and continue searching. And maybe what I was trying to create - an artificial structure that could manipulate beams of light in the same way that silicon and other semiconductors control electric currents - was not possible at all.

- Eli Yablonovitch  
Scientific American  
December 2001

## The Seeds of a Revolution: Birth of Photonic Crystals

The microelectronic and telecommunication industry saw a revolution with the evolution of semiconductors such as silicon, which provide an elaborate control of electric currents. The control is achieved through the band gap property of the material, a range of energies in which electrons are prohibited from propagating. The silicon revolution led to the birth of transistors and Integrated Circuit(IC) technology, which revolutionized the world of Computing, Communications and Information technology. But by the late 20th century, electronic designers had almost realized the theoretical limitations of the speed and bandwidth possible with this technology and the quest for an alternate solution was urgent.

Photonics was a solution. Photonics uses photons or light in the visible and infra-red region for carrying information. By shifting to frequency ranges much higher than radio and microwave frequency, it promised a greater bandwidth. With the invention of Lasers in 1960s and the optical fibers in the 1980s, photonics had started making its presence felt. However there was an immediate need for some kind of material which would act as the semiconductors of light and make possible the control of photons in a way similar to the control of electrons made possible by semiconductors. This quest led

# Photonic Crystals

## Semiconductors of Light

to the discovery of photonic crystals.

It happened in 1987 at the Bell Communications Research. Eli Yablonovitch, working on making telecommunication lasers more efficient, was seeking periodic dielectric crystals which would exhibit band gap property very much like the band gap properties arising in atomic lattices of silicon and other semiconductors. A typical example of such a material would be a block of special glass drilled through with a closely spaced array of cylindrical holes, each with diameters in the range of hundreds of nanometers. Light entering this holey material will undergo reflections and refractions at the myriad interfaces between air and the glass. The complex pattern of overlapping beams will reinforce or cancel each other depending on the wavelength of light. After struggling for almost four years by designing crystals with various permutations and combinations of periodicity and symmetry and drilling more than 500,000 holes through various dielectric materials, Yablonovitch and his team demonstrated the first successful photonic band gap crystal in 1991. That particular crystal structure was christened Yablonovite and such materials in general came to be known as photonic crystals.

The photonic crystals are functionally very much analogous to the semiconductor crystals. In semiconductors, the Schrödinger equation for the electron wave function is casted as an eigen-value problem; in photonics, it is the Maxwell's equation for the Electric and Magnetic field that plays this role. The periodic potential of the semiconductor crystal leads to photonic band gaps. Similarly it is the periodicity in the dielectric property of

six PCBs are fabricated per week. This number increases drastically during the EDP/EDL or during submission time mostly around Oct/Nov and Mar/Apr. Since renovation, the number of students availing these services is steadily increasing. Earlier, there was provision for making only single sided PCBs but post-renovation, manufacturing of multi-layered PCBs has commenced which is one of the major reasons in the increase of the lab's utilization. The reason for the lack of awareness about the available facilities is perhaps the fact that the lab is not associated directly with any course.

**Is the quality of PCBs made comparable to the ones that are made in the**

photonic crystals that leads to the photonic band gaps. However there is one major difference between the two. While in semiconductor crystals the periodicity is restricted to atomic distances; for the photonic crystals, this periodicity is scalable and in the hands of the manufacturer. Thus by scaling the periodicity the crystals, the band gaps can be obtained in radio and microwave frequencies as well.

### The Revolution Anticipated: Applications and Vision

It is now learnt that band gap structures are also found in nature - in the sparkling gems of opal, the colorful wings of butterfly and in the hairs of a wormlike creature called the sea mouse. A large number of photonic crystals, with periodicity in one, two and three dimensions have been fabricated in labs all around the world and have found applications in diverse fields.

**Photonic Crystal Fibers(PCF):** 2D band gap material which restricts light of a given frequency from travelling in a plane can be stretched along the third dimension to form a new kind of optical fiber. Electromagnetic modes in these fibers would be guided due to the photonic band gap effect rather than total internal reflection. The losses and dispersion effect are minimized in these fibers. These micro structured fibers, known popularly as holey fibers have already gone commercial.

**Channel waveguides:** By removing rows of holes from an otherwise uniform pattern a line defect is created. These would behave like optical quantum well and can guide light along the line.

**Nanoscale Lasers:** Photonic crystals with point defects leads to "micro cavities", which generate a narrow so-called

**market?**

With the addition of the rapid prototyping technique, the quality is very much similar to PCBs manufactured outside.

### Is the manual chemical etching process still popular?

The manual process involves printing the circuit, UV photo-printing, scrubbing, etching and drilling. On account of this being a manual process, reliability and accuracy are not very high for complex circuits. But nevertheless, it is employed for simpler circuits where the manual drilling of holes and shaping of tracks is manageable. Both the manual and automatic processes on an average take one day to manufacture a

defect mode. They can be used to make nano Lasers and LEDs that would emit light in a very narrow-bandwidth, together with highly selective optical filters. These tiny lasers acting as the modulating source, the channel waveguides acting as optical interconnects and the photonic crystal fiber can be integrated together to form an efficient optical communication system. Another application of these crystals in the field of optical communication networking is in making **all-optical switches** which does the routing and the header processing in optical domain, thus avoiding the need for optical-to-electrical-to-optical conversion at the router and switching junctions.

**Optical Transistors:** A phenomenon called Kerr nonlinearity can be exploited in the photonic crystals to exhibit bistability. This has been shown experimentally and may lead to the birth of optical transistors, which would bring the next big revolution since the invention of the BJT.

The next step then obviously, learning from history, would be the **photonic Integrated Circuits**. The ultimate aim would be to replace all electrons with photons and all semiconductors with photonic crystals. The vision is to have, one day, a computer which has a processor made of photonic crystal - a generation of computers, computing at speed in hundreds of terahertz, millions of times faster than the present generation computers.

Much research has been done in this field over the last decade. The topic still remains a hot area of academic and industrial research. Interested readers may look at <http://www.pgblink.com> for more details. Even in IIT Bombay active research is being pursued in this field in the Dept. of Electrical Engineering, under Prof. R.K.Shevgaonkar and in the Dept. of Physics under Prof. R. Vijaya and Prof. B.P. Singh.

*Adnan Raja is 3rd Year B.Tech. student. He can be contacted at [adnan@ee.iitb.ac.in](mailto:adnan@ee.iitb.ac.in). The author would like to thank Uday Khankhoje (4th Year B.Tech) for his useful inputs and feedback.*

PCB. The type of technique to be used for making the PCB can be specified while filling out the form.

### What are the major problems being faced in the present scenario?

The only major problem is the scarcity of support staff. There used to be 5 employees earlier but after retirements, just two full time workers are left now. They have to handle both the manual process and the prototyping process, which becomes arduous and hard to deal with during the EDP/EDL period, taking into account the number of applications coming in during this period. Otherwise, from the infrastructure point-of-view, this lab is very well-equipped for its targeted objectives.

## Know Thy Turf

(Continued from Page 7)

The entire operation takes around 8 hrs for pressing, and 6 hrs for cooling. This machine is controlled by a micro-processor based lamination press. The Multipress II combined with ProtoMat and Minicontac II (for PTH) provide a complete in house PCB prototyping facility.

# 8

**What is the level of usage of the facilities in the lab?**

On an average



# Spectrum



Come every summer and students, especially sophomores, are busy pondering as to how to spend their vacation time productively and hunting for much sought-after “projects” to be pursued during the holidays. Also, in recent years, the advent of the UROP has provided UG students with an excellent opportunity to explore their aptitude in research. A few words about UROP first: UROPs are aimed to provide UG students who have good academic performance, an opportunity to get research experience by involving them in the ongoing research projects. The UROPs are categorized into sublevels: UROP01, 02 and 03. Both B.Tech. and DD students are eligible to pursue UROP01 which has no credits. The second and third levels, UROP02 and 03, for which only B.Tech. students are eligible, can be done in place of the final year degree project. To ease the process for the interested students, Vivek Mishra of Background Hum talked to professors in the department and compiled a list of projects available for the students.

Prof. V.M. Gadre gave details of the projects under his supervision. Currently, his research focus is on Fractional Fourier Transforms. Quadratic chirp characterization with Fractional Fourier Transforms was done by Uday Khankhoje under UROP01. Further, Harshad Kasture and Supreet Joshi

## Check 'em Out!

broadly worked on a method of Fractional Fourier domain moments for characterizing linear and quadratic chirps. Arijit Sarkar and Jayakrishnan Unnikrishnan, worked on the use of wavelets in neural networks for time series analysis. Currently, two second year students, Prateek Gupta and Praneeth, are studying the detection and characterization of properties of Fractional Fourier Transform together with other transforms like Short Time Fourier Transform.

Switching to microelectronics, Prof. Souvik Mahapatra is working on Negative Bias Temperature Instability (NBTI) degradation in MOSFETs. Mohit Gupta, a sophomore, is studying the effects of the addition of various elements like boron, hydrogen, deuterium, nitrogen, fluorine etc. Studying this degradation is important because it can result in delays and unexpected device failure. Developing a model for this degradation is indeed a challenging job. Flash memories are another area of interest for Prof. Mahapatra. CMOS used in flash memories can change the fate of the presently used hard disks. Who knows 5-10 years down the line we might have easy to read, write and

erase portable flash memories instead of hard disks.

Moving onto Controls and Computing, there is a lot of interesting stuff going on here as well. Prof. Preeti Rao & Prof. Sumantra Dutta Roy have floated a topic titled “Robust Music Information Retrieval Modeling, Search and Performance Evaluation”. A brief description of the project as given by Prof. Sumantra follows: “Current search methods and search engines are primarily text-based. Our plan is to look at the concept of Query-by-Humming, wherein the user hums a song phrase, and the system retrieves the closest match. Apart from the basic signal processing, there is a good deal of system modeling involved to initiate a search based on part of a phrase in the song which itself may have errors, evolving efficient schemes for representation of songs in the database and developing efficient retrieval strategies. The coding for the algorithm development will be in C so as to link it with the current code base.” The prerequisites for the project are a good knowledge of coding. An interest in music will be appreciated.

## AWARDS

**Prof S Chaudhuri** has been awarded Shanti Swarup Bhatnagar award in Engineering Sciences for the year 2004 for his seminal work in the area of computer vision.

**Prof V Ramagopal Rao** has been selected for the prestigious Swarnajayanti fellowships awarded for the year 2004.

**Prof S Mahapatra** has been selected for the prestigious INAE Young Engineer Award in recognition of his outstanding contributions in teaching, innovative development and engineering research in Electrical Engg.

**Prof U B Desai** has been elected as a Fellow of the Indian National Science Academy for the year 2004.

**Prof T S Rathore** received the award the IETE Prof SVC Aiya Memorial Award (2004) in recognition of his distinguished contribution in electronics and telecommunication research.

IRCC Award: Dr P K Patwardhan Technology Development Award - 2004 for innovative R&D was given to **Prof A Karandikar** for “Multiprotocol Label Switching Router” (MPLS)

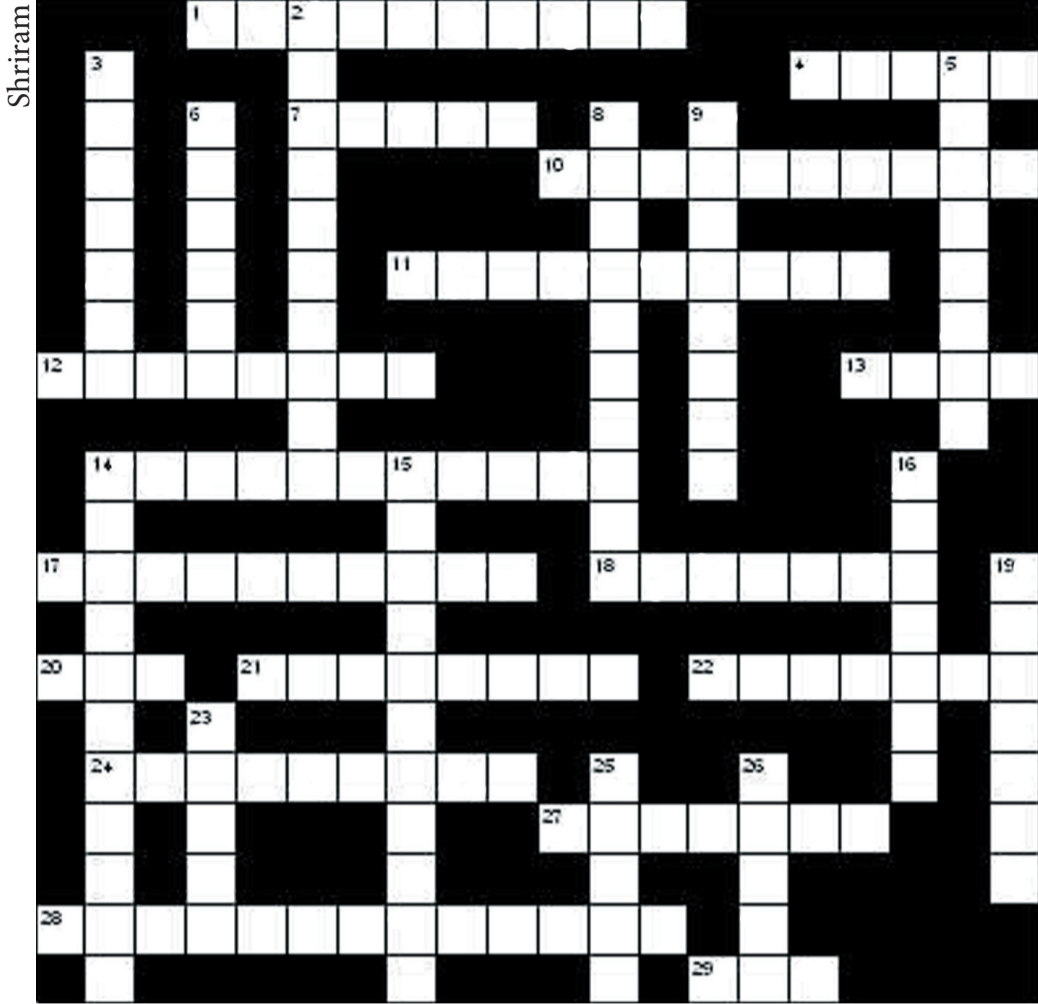

**ACROSS**

- 1. Dancers' rut transforms into electrical signals
- 4. Sinusoidally twisted figure
- 7. Crazy remix
- 10. Warm voices sing at high frequencies
- 11. A stoic roll or rise and fall?
- 12. Something ten French girls are crazy about
- 13. If and buts reversed matches loads
- 14. A comets' apron improves transients & PF!!
- 17. "Math! Christ, that makes me see circles!!"
- 18. Transport vehicle converter
- 20. Chuck out the high court for a change
- 21. Networks can inspire you to relate legends shortly
- 22. Can any quisling drinking tea decide about stability?
- 24. Impair elf who increases strength?
- 27. Waves could not have felt better!!
- 28. Crazy, a blocker two-up can see no more!!

29. Crossbones or a gate??

**DOWN**

- 2. A tinted cam allows easy passage
- 3. Of this gaunt mathematician who was initially persecuted
- 5. Broken glasses mixed with alcohol provide a broad range
- 6. Noise when they strip pleasingly
- 8. Dire Celtic omens portend polarization
- 9. Excite a novice's right to seize power
- 14. Endless communist at a headless station likes DC motor operation
- 15. Noticed in a gifts' mall sign albeit as an approximation
- 16. Your humour splits frequency at the roots
- 19. Madly halt CPU to lose gate control
- 23. Fish sacrifices tail fin in exchange for miraculous simulation powers
- 25. A lab is turned weirdly upside down in France due to mismatches
- 26. Mechanical control mixed up in cricket parlance

**A**t the same time as I decided to do my exchange year in Bombay, my flat mate decided to study one year in Tenerife – a Spanish island which is a famous tourist destination with sun, sand and sea. We imagined that he would be surfing while I would be studying and learning mathematical formulae by heart. Well, the prospect of lying on the beach was tempting for me too, but I was too much interested in India, so I chose to spend my exchange year in Bombay.

When I reached Bombay, the place was different from what I'd imagined. In some ways, perhaps unconsciously, I expected to meet a lot of boring people in not very colorful shirts working all day. At least I expected something in that direction. Instead, I got to know the Indians as very festive, open, tolerant, self-conscious, interesting and free people.

A big difference between EPFL and IIT is life on the campus. EPFL is a campus for studies only, at least until now. There are no hostels on the campus itself and most of the students live in one of the surrounding cities or villages. Some have to take the train or car to get to EPFL. There is no night-life on the campus. In IIT, there are a lot of possibilities to enjoy the free time with friends. Activities like PAF and Mood Indigo (which I missed unfortunately) were a nice change from daily study life. I think life on campus creates an atmosphere that is also helpful for studies and research. The whole IIT community was like a huge family

for me, where you can trust everyone. Especially for me, as an exchange student, this was very important. On the other hand, it was difficult for me to get some distance from studies, as life is always happening very close to classrooms and labs.

The way of studying is also a bit different. Compared to IIT students, EPFL

students have much more responsibility. No one controls if people do their homework or if they go to classes. If someone doesn't take his responsibility, he will fail the exams and repeat one year, or sometimes it is even impossible to continue studies in EPFL.

During my initial years in EPFL, I used to go to bed at 10 PM in the eve-

ning before an exam, and before that I'd watch a movie or read a book to relax. I used to prepare for my exams during the semester. Unfortunately I never managed to do so in IIT, probably because of the influence of the other students. Everybody was joking about me because I used to go to bed around PM :- ) I never understood how IIT students can watch so many mov-

ies during the semester, study the night before the exams and still get good results. There are some brilliant people in IIT. Only in the second semester, I managed to get a grade I am proud of. Unfortunately, teamwork never really worked in my groups in the same way as it usually does in Switzerland. There were always one or two people who did the whole work and others who, at most, supported them mentally.

I met my flat mate again after my exchange year. He has learnt how to surf, and he's missing it. I'm surely not missing learning the formulas by heart, but I'm surely missing my friends at IIT. Studies would have been easier if I had done all of them in Switzerland. Perhaps, I would have learnt more. But I wouldn't have had the wonderful experience, the chance to see India with other eyes than the one of a tourist, to get to know many nice people, and to know "another way of doing it".

I take advantage of the opportunity to thank all the people who helped to make my exchange year an unforgettable one. I miss the swimming, playing water polo, going for treats, chatting, studying, eating etc. with you. Thank you for the wonderful time.

*Tobias Thunherr was an exchange student in our department from EPFL, Lausanne, Switzerland during the last academic year 2003-04.*

<b>loonEEy Toons</b>			<b>by Suddu</b>
<p><b>CURRENT BOOKING</b></p> <p>ONLY EE</p> <p><b>HOUSE FULL</b></p>	<p><b>WEL LABS</b></p> <p><b>ADVANCE BOOKING</b></p> <p>ONLY EE</p>	<p><b>NON-EE BOOKINGS</b></p>	<p><b>NEXT SLOT:</b></p> <p><b>1 AM - 4:30 AM</b></p> <p><b>SCREENING:</b></p> <p>TABLE1: <b>MicroMouse</b></p> <p>TABLE2: <b>EDP</b></p> <p>TABLE3: <b>EDP</b></p> <p>TABLE4: <b>DNA chip</b></p> <p><b>BOX OFFICE HIT:</b></p> <p><b>EDP</b></p>
 <p>ek se chaar ek se chaar</p>			